

Military Custom Off-The-Shelf Power Supply MVM-174-51-4H

174W Quad Isolated Outputs DC-DC Power Supply High Dynamic Loading Output for Radar Systems

Main Features

- Meet MIL-STD-167-1A/ 810G/ 461G
- Vin: 48Vdc \pm 15%
- Vout: 3.8/ 5.5/ -5/ 51Vdc
- 51V 30A peak (3A AVG): Output Voltages Ripple: 50mV
- 51V Output within 1V max droop during pulse of 30 usec
- ESD: \pm 8KV Contact Discharge; \pm 15KV Air Discharge
- Signals: PS_SYNC/ PS_OK/ LOGIC_GND/ PS_ON/OFF
- External Sync. Capability/ Synchronize Lock
- Digital Controls and Sense
- Operating Temp: 0°C to 50°C
- Pass 20G Mechanical Shock
- Conduction Cooled
- EMI Filters Included
- Led Indicate Display
- Low Profile Size – 270 mm (L) x 147 mm (W) x 20 mm (H) (I/O Connector not included)

Typical Applications

- Military Airborne/ Ground-Fix/ Shipboard
- Ground Vehicle Radar Communication
- UAV (Unmanned Aerial Vehicle)



Military Custom Off-The-Shelf Power Supply MVM-174-51-4H

Electrical Characteristics

Parameter	Limit or Range		Conditions Or Remarks
Input voltage	48V +/- 15%		
Max. Input Power	190W		At nominal input voltage and full output power
Input Ripple Current	Below 5% @ Max Load		
Line Regulation	Less than 2%		
Output Voltages	+51V	51 ± 0.5V	Measured under any load Variation over 20hz – 20Mhz
	-5.0V	-5.0 ± 0.1V	
	+5.5V	+5.5 ± 0.1V	
	+3.8V	+3.8 ± 0.1V	
Max. Output Current	+51V	30A peak (3A AVG)*	(*) Max P.W 30µSec D.C 10% Across 1600µF(X2) capacitors PRF >500hz
	-5.0V	0.5A	
	+5.5V	2.5A	
	+3.8V	1.1A	
Current Limit Protection	Current limit protection will be Activated at 120% above the Nominal Currents		
Output Voltages Ripple	+51V	50mV	Measured under any load variation over 20Hz – 20MHz.
	-5.0V	10mV	
	+5.5V	10mV	
	+3.8V	10mV	
Over / Under Voltages Protection	Over Voltage protection will be Activated at 120% above the Nominal Voltages		
Pulse Load	51V Output shell be within 1V max droop during pulse of 30 usec		Measured at: Max. P.W 30 µSec Across 1600uF (x2) capacitors
EXT Sync	350 – 450 KHZ Frequency Duty Cycle 50% ±10%		Internal frequency: 375KHz ±5%
Inrush Current			See para. 3.8.1 section 8
Efficiency	Mini. 90 % at full load (at nominal input voltage)		
Cooling method	Conduction to cooling base plate of 70°C. (Indirect through the frame of PS)		
<u>Isolation resistance</u>	<u>resistance</u>		<u>@voltage</u>
Input-Output	100MΩ		200VDC @ 25°C
Input-chassis	100MΩ		200VDC @ 25°C
Output-chassis	100MΩ		100VDC @ 25°C

Military Custom Off-The-Shelf Power Supply MVM-174-51-4H

Power Supply – Block Diagram

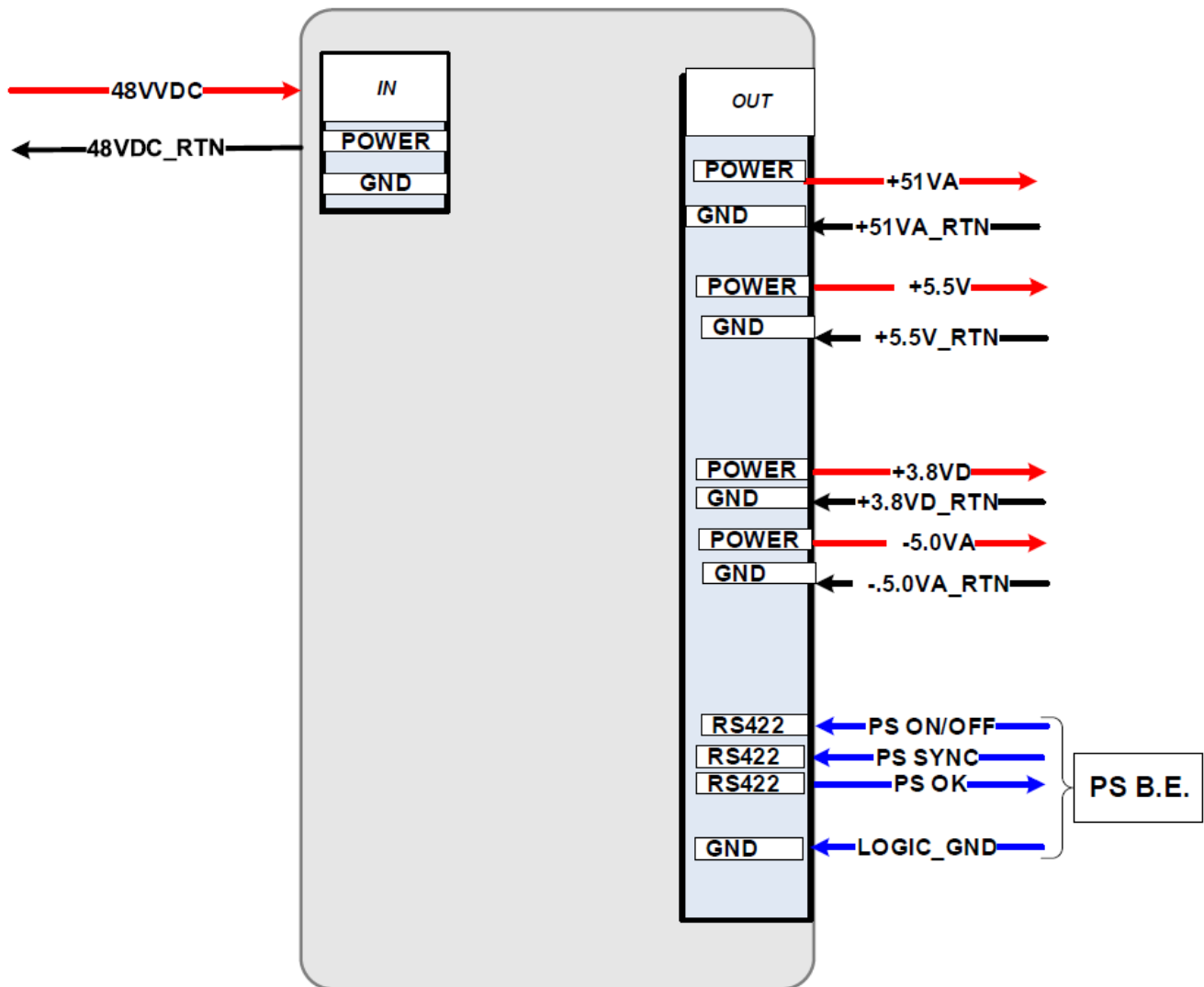

Input voltage requirements

- 1 Power supply 48VDC \pm 15%VDC
- 2 Permissible Inrush current

The inrush current shall not exceed 1.3 x I Nominal.

The rise time of the inrush current shall not be faster than 3mSec.

Military Custom Off-The-Shelf Power Supply MVM-174-51-4H

The Output electrical requirements

- 1 Load capacitor - For +51V outputs, there should be a 2x1600uF integrated (Total 3200uF), where the pulse current should be for pulse with 30usec and duty cycle 10% for 30A peak.
- 2 Ripple and Noise shall be measured over a minimum frequency band of 30 Hz to 20 MHz.
- 3 Droop - The power supply will supply the current required so the maximum droop at 30usec pulse width will not exceed 1V. The capacitor bank should be implemented at Load.
- 4 All the output will floating each other.
- 5 All outputs shall be independent and not be influenced by any other output.
- 6 The power supply shall not suffer any damage under short circuit or overload and shall recover upon removal of the overload.
- 7 Power supply output ripple - The output voltages will not change within specified ripple when the prime power input is within specified Voltage para 3.3.
- 8 In case of a failure of any output, The PS shuts down according to shutdown sequence (see detailed in par. 3.3.3.) Except 3.8v which will continue to operate
- 9 Load scenarios which the PS supports for continues operation:
 Load can vary from DC load to pulse widths in any duty cycle, while average current consumption is within spec (at 51V output). A transition between burst of short pulses (2μs) to long pulses (30μs) in any duty cycles up to 10%.
- 10 No degradation in performance due to load changes as mention above.
- 11 The PS will be tested with dynamic loads which will simulate all the above mention (D.C, PRF).
- 12 In a case of sudden output voltage drop and rise of the main 51VDC outputs ("hiccup process"), the PS will send a warning indication in the BIT of the unit.
- 13 The P.S shall be capable of maintain the specified requirements under the entire of environmental condition, input power, sources and output load.
- 14 Output Capacitance:

The following table describes the total output capacitance for each output voltages

Output	Total Load Capacitance	Note
+51V		1600uF (x2) Integrate in P.S
-5.5V	10μF	
+5.5V_D	10μF	
+3.8V	10μF	
+5.5V_A	10μF	

Military Custom Off-The-Shelf Power Supply MVM-174-51-4H

Operation Sequence

The -5.0V is a critical supply voltage to the module, therefore it should ramp up and down according to the following sequence description.

Power up

First Voltage to be turned ON is -5VA.

Then +3.8VD, +5.5V and the last is the +51VA.

Power up sequence

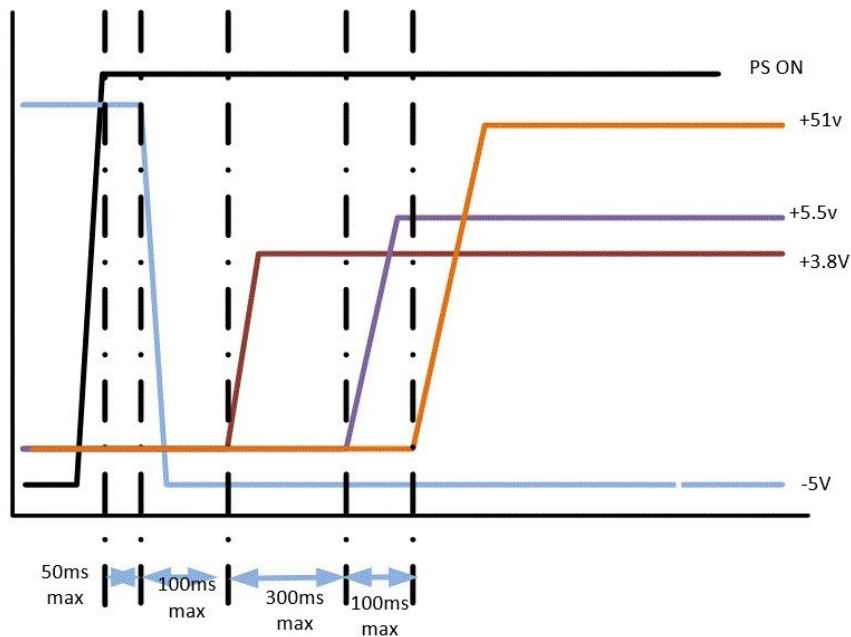

Power down

First Voltage to be turned OFF is +51VA Then +5.5V, +3.8VD

Then the last is the -5VA.

Power down sequence

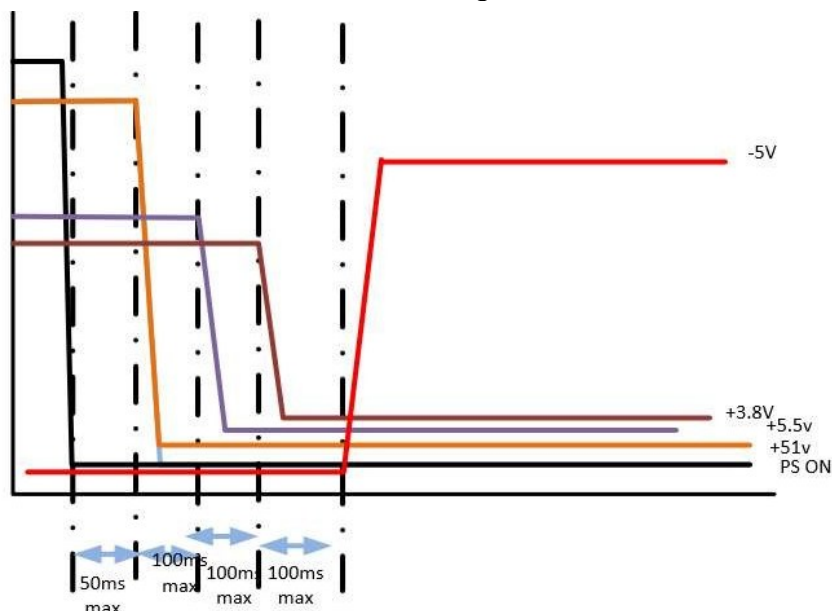

Military Custom Off-The-Shelf Power Supply MVM-174-51-4H

Synchronization Characteristics

The switching module of the P.S. shall be synchronized with an external frequency source. In the event of the external source not supplying or out of range the appropriate frequency the power supply shall operate on its own internal free running frequency source.

The frequency sync may be switched from Ext. to Int. There will be no degradation in the Electrical performance. The power supply will be stabilized within 1000usec. When the sync frequency changes the output voltages including transient will not exceed $\pm 3\%$ of regulation range.

Frequency Operation:

- 1 PS_SYNC frequency source range: 350 ÷ 450 KHz.
- 2 Duty cycle: 50% \pm 10 %

Notes:

- 1 When the sync frequency is changed, the output voltage including transient voltage will not exceed the regulation limits as defined in Table 3.
- 2 The output voltage levels shall not deviate from the above defined levels in either transition FROM or TO the External Sync.

Temperature warning & shut down

P.S. conducted to cooling base plates of 70 °C. In case of rising temperature, the power supply will indicate and protect himself as follow:

- 1 Over temperature warning threshold shall be activated 10°C under the shutdown temperature.
- 2 Over temperature shut down shall be activated when max allowed temperature appears.
- 3 P.S Shall be Non-Latching and Auto recovery when the temperature falls below 15°C under the shutdown temperature.

Military Custom Off-The-Shelf Power Supply MVM-174-51-4H

Environmental

The P.S shall fully comply with all specification requirements while and after being subjected to any combination of the environmental conditions specified below.

Environment	Non-Operating	Operating	Applicable Standard
Ambient Temperature	-33°C to 71°C	0°C to 50°C	MIL-STD-810H, Methods 501.7 & 502.7, Procedures I & II
Humidity	Up to 95%RH (including condensation)		MIL-STD-810H, Method 507.6, Procedure II (aggravated cycles)
Salt Fog	Salt exposure to 5% NaCl for 24x2 hours and storage for 24x2 hours		MIL-STD-810H, Method 509.7
Fungus	Fungi-inert materials shall be used		MIL-HDBK-454B, Guideline 4
Degree of Enclosure	Drip-proof		MIL-STD-108E
Vibration	Transportation, US High Way profile per MIL-STD-810H	Shipboard (Mast-mounted), per MIL-STD-167-1A	MIL-STD-810H, Method 514.8, Category 4, US HIGH WAY; MIL-STD-167-1A, Type I
Mechanical Shock	For electronic equipment: sawtooth, 20g, 11msec, 18 shocks		MIL-STD-810H, Method 516.8, Proc. I

Military Custom Off-The-Shelf Power Supply MVM-174-51-4H

EMI/EMC Requirements

The P.S shall fully comply with all specification requirements while and after being subjected to any combination of the EMI/EMC conditions specified below

#	Test	Description	Limits & Comments
1	CE106	Conducted Emissions, Antenna terminal 10KHz - 40GHz	For receivers & transmitters
2	CS114	Conducted Susceptibility, Bulk cable Injection 10KHz to 200MHz	
3	CS115	Conducted Susceptibility, Bulk cable Injection, Impulse Excitation	Figure CS115-1, I _{max} =5A
4	CS116	Conducted Susceptibility, Damped Sinusoidal Transients, Cables & Power Leads 10KHz to 100MHz.	Figure CS116-2, I _{max} =10A
5	RE101	Radiated Emissions, Magnetic Field 30Hz – 100KHz	
6	RE102	Radiated Emissions, Electric Field 2MHz – 18GHz	
7	RS101	Radiated Susceptibility, Magnetic Field 30Hz – 100KHz	
8	RS103	Radiated Susceptibility, Electric Field 2MHz - 18GHz.	For ground platform 50V/m For navy platform 200V/m
9	ESD	According to IEC 61000-4-2, Level 4	±8KV Contact Discharge ±15KV Air Discharge

Military Custom Off-The-Shelf Power Supply MVM-174-51-4H

Mechanical Outline Size

Weight – 0.9 kg

Size – 270 mm (L) x 147 mm (W) x 20 mm (H) (I/O connector not included)

Cooling – Base plate

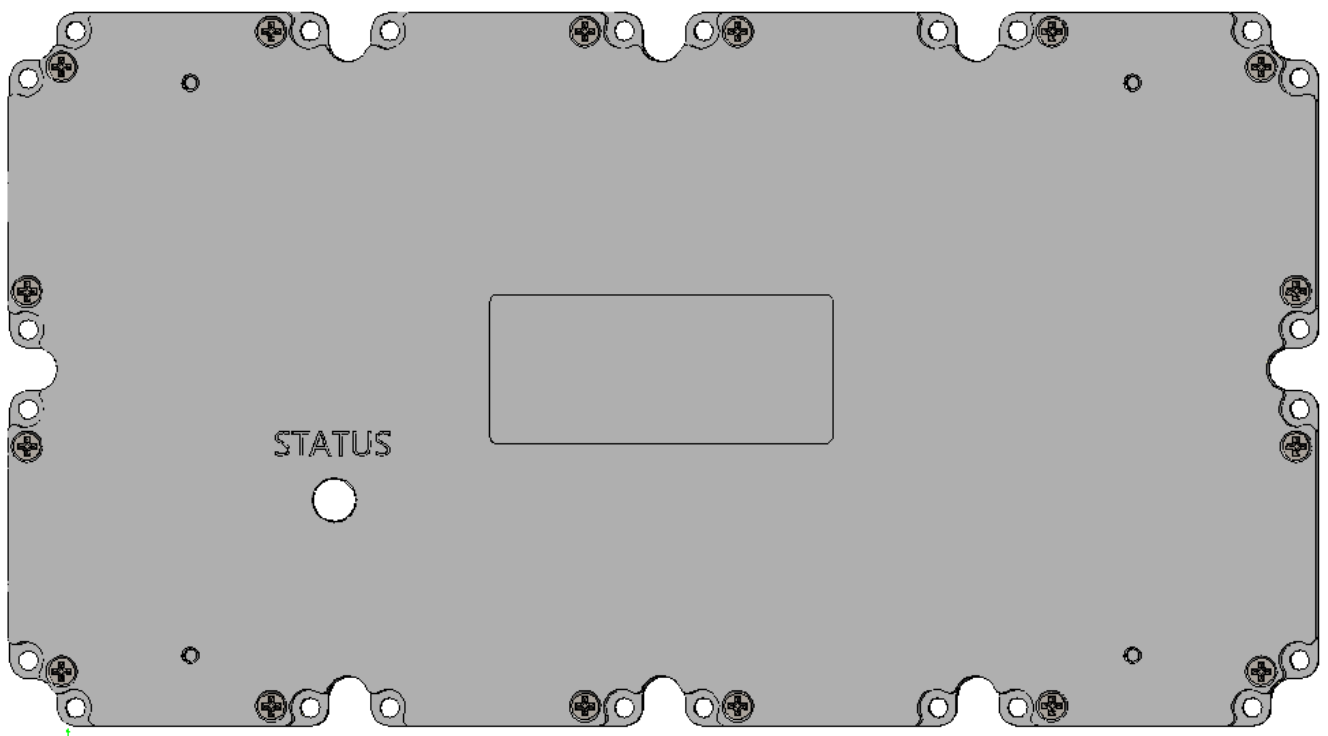
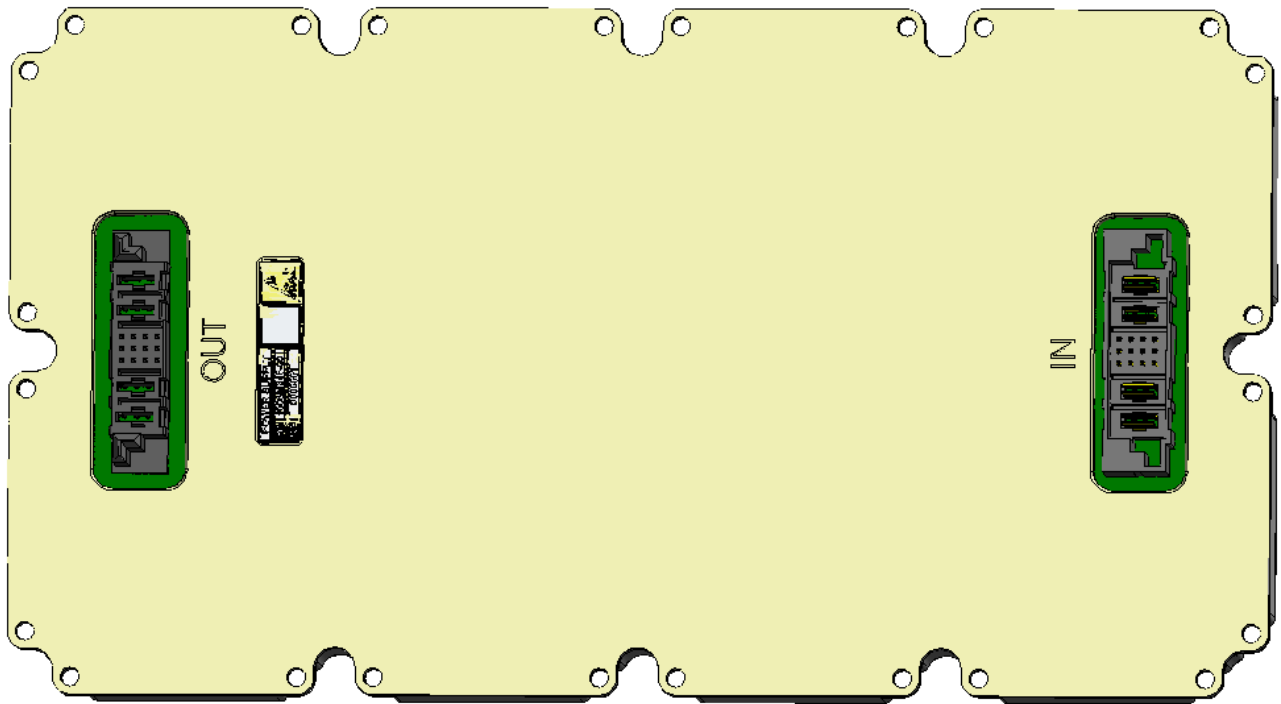

Military Custom Off-The-Shelf Power Supply MVM-174-51-4H

Connectors & Pin Assignment

Pin assignment: - Power IN Connector - J1

Designation	Part Num.	Mated to.	Current Rating
J1	PESC-02-12-02-01-S-VT		TBD

J1 - Power IN Connector Pinout

PIN No.	PIN NAME
01 power	48VDC
02 power	48VDC
03 power	48VDC_RTN
04 power	48VDC_RTN
01 SIGNAL	PS_ON/OFF_P
02 SIGNAL	PS_ON/OFF_N
03 SIGNAL	
04 SIGNAL	
05 SIGNAL	
06 SIGNAL	
07 SIGNAL	
08 SIGNAL	
09 SIGNAL	
010 SIGNAL	
11 SIGNAL	
12 SIGNAL	

Military Custom Off-The-Shelf Power Supply MVM-174-51-4H

Pin assignment: - Power OUT Connector – J2

Designation	Part Num.	Mated to.	Current Rating
J2	PETC-02-12-02-01-S-VT		TBD

J1 – Power OUT Connector Pinout

PIN No.	PIN NAME
01 power	51VDC
02 power	51VDC
03 power	51VDC_GND
04 power	51VDC_GND
01 SIGNAL	-5VDC
02 SIGNAL	-5VDC_GND
03 SIGNAL	3.8VDC
04 SIGNAL	3.8VDC_GND
05 SIGNAL	5.5VDC
06 SIGNAL	5.5VDC_GND
07 SIGNAL	
08 SIGNAL	PS_SYNC_P
09 SIGNAL	PS_SYNC_N
10 SIGNAL	PS_OK_P
11 SIGNAL	PS_OK_N
12 SIGNAL	LOGIC_GND

Military Custom Off-The-Shelf Power Supply MVM-174-51-4H

Discrete Signals General

The power supplies have discrete outputs that supply information about each power supply status. The line drive (RS 422) referenced to the return line of the LOGIC_GND of the power supply. Status signals are fed from separate auxiliary voltage and are valid after power supply turns on.

LOGIC GND

The LOGIC GND is a ground reference for signals which are connected to the 3.8V In the BE(As shown block diagram)

PS SYNC

The power supply is synchronized from external generator. Without sync, the power supply will run with internal sync. A differential input RS422 signal referenced to the return line of the +3.8V in the power supply. If the external synchronization signal fails the power supply will run with internal sync (350 – 450 KHz).

Direction: Input.

Type: RS-422.

PS OK

The PS_OK is a logic signal that indicates that All the P.S. output voltages are stable within and no protections activated.

This signal is normally high and it driven low when one or more of the voltage outputs step from the limits for more than 200[μ s] duration.

Direction: Output.

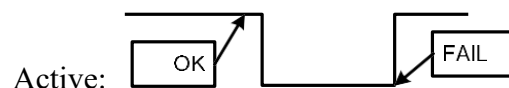

Type: RS-422

LED INDICATE DISPLAY

At the front panel will be LED INDICATE

GREEN- PS OK

RED – PS FAIL

Military Custom Off-The-Shelf Power Supply MVM-174-51-4H

PS ON OFF

Power supply turn ON shall be accomplished by activating “ON/OFF” line.

The signal shall be valid if and only if it holds its level for at least 100mS.

The differential input signals will be supplied through RS-422, in the power supply.

Direction: Input.

3.3V = ON

0V = OFF

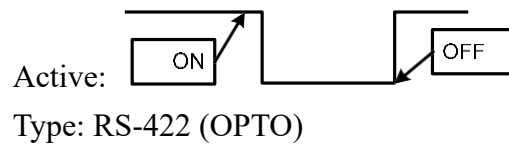

Reliability

Mean Time between Failures (MTBF)

The predicted MTBF of the module shall be of 200,000 hours at least, when calculated in accordance with MIL-HDBK-217F, Parts Stress Analysis method, for the Ground Fixed (GF) environment and ambient temperature of 25°C.